

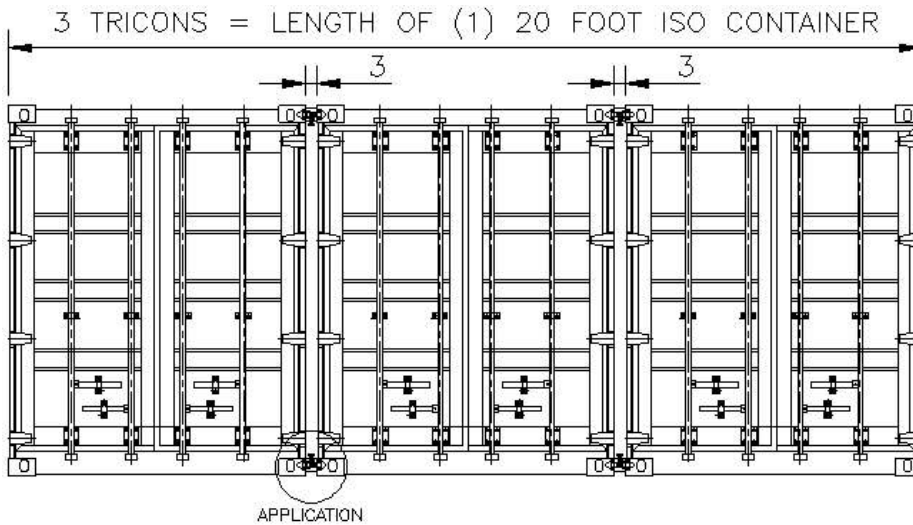

SEA BOX[®]

Horizontal Twistlock

SB341
Horizontal Twistlock

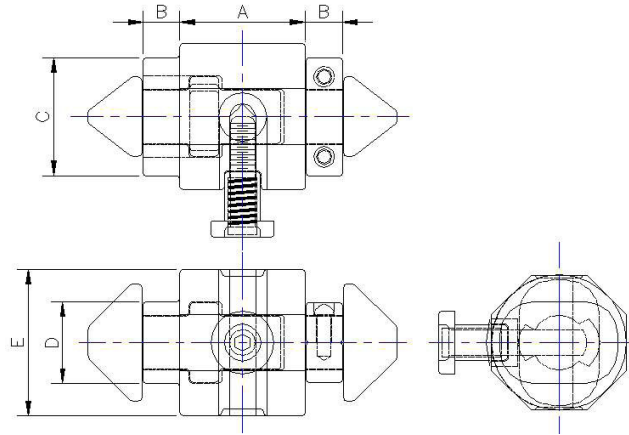

PRODUCT SPECIFICATIONS

- Material forged steel
- Finish hot dipped galvanized
- Capacity safe working load 12 ton tension
- Rated capacity tension 27 tons
- Rated capacity shear 8.3 tons
- Rated capacity compression 20.8 tons
- Tare weight 10.5 lbs, 4.76 kg

STANDARD PRODUCT FEATURES

- Compatible with all ISO type containers

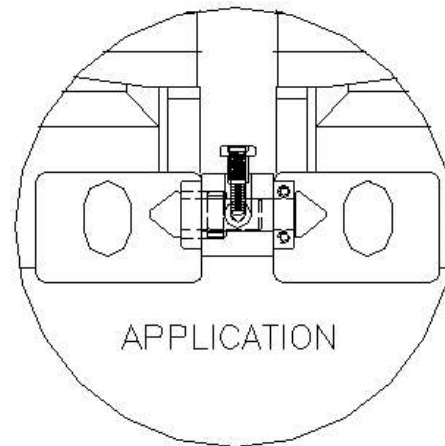

061308-R00

ISO 9001:2008



CERTIFIED QUALITY
MANAGEMENT SYSTEM

CONTRACT # GS-02F-0024P
GSA Advantage![™]

DIMENSIONAL INFORMATION

	A	B	C	D	E
Inches	3"	0.88"	2.75"	1.88"	3.5"
Metric	76	22.2	70	47.6	89

ALL DIMENSIONS AND WEIGHTS ARE NOMINAL AND SUBJECT TO MINOR VARIATIONS THAT MAY OCCUR DURING THE MANUFACTURING PROCESS