

Sea Box, Inc.

CORPORATE OFFICE
 802 Industrial Hwy.
 East Riverton, NJ 08077-1910
 Tel: (856) 303-1101
 Fax: (856) 303-1501
www.seabox.com
 e-mail: sales@seabox.com

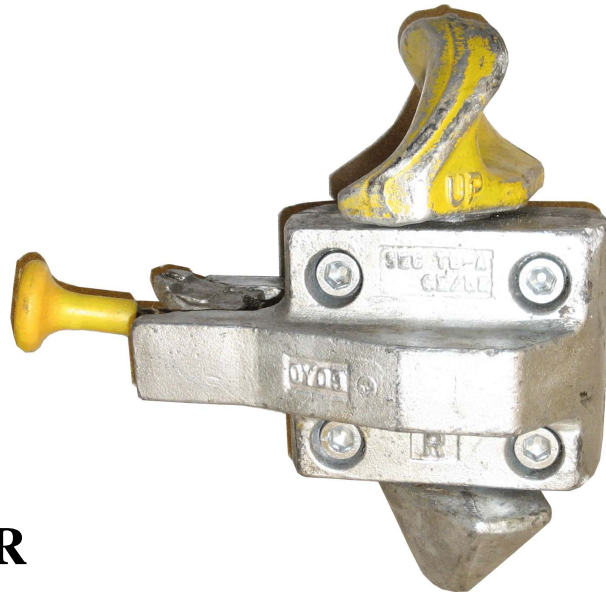

VERTICAL TWISTLOCK STACKER

**This item can be used to stack
 ISO Containers**

- SPECIFICATIONS —
- ▶ Tension Breaking Load: 50 (M.ton)
 - ▶ Shear Breaking Load: 40 (M.ton)
 - ▶ Lifting SWL: 10 (M.ton)
 - ▶ Compression SWL: 100 (M.ton)
 - ▶ Weight: 6.7kg

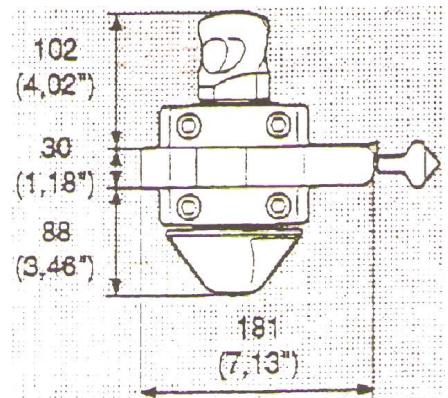
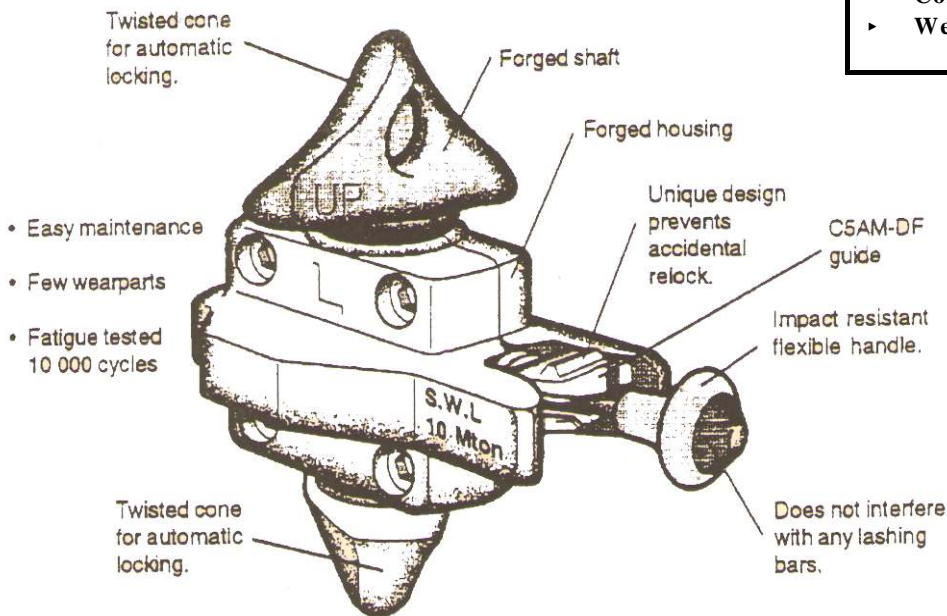

PART # SB441