

Sea Box, Inc.

CORPORATE OFFICE
 802 Industrial Hwy.
 East Riverton, NJ 08077-1827
 Tel: (856) 303-1101
 Fax: (856) 303-1501
www.seabox.com
 e-mail: sales@seabox.com



10" Swivel Polyurethane Caster with Twist Lock

CASTER	DIMENSIONAL INFORMATION							
	A	B	C	D	E	F	G	H
INCHES	10"	3"	7 3/8"	11 3/4"	7 1/4"	7 1/8"	5 9/32"	4 1/8"
METRIC	254	76.2	187.3	298.5	184.2	155.6	134.1	104.8

— FEATURES —

- ▶ Zinc plated finish
- ▶ 3/4" dia. Axle bolt w/ locknut
- ▶ Zerk grease fitting in axle & raceway
- ▶ Capacity max working load 3,000 lbs.
- ▶ Top plate & yoke drop drop forged steel
- ▶ Polyurethane over steel wheel
- ▶ Rotates full 360 degrees

— Options —

- ▶ Position lock
- ▶ Wheel brake
- ▶ Deck mount twistlock

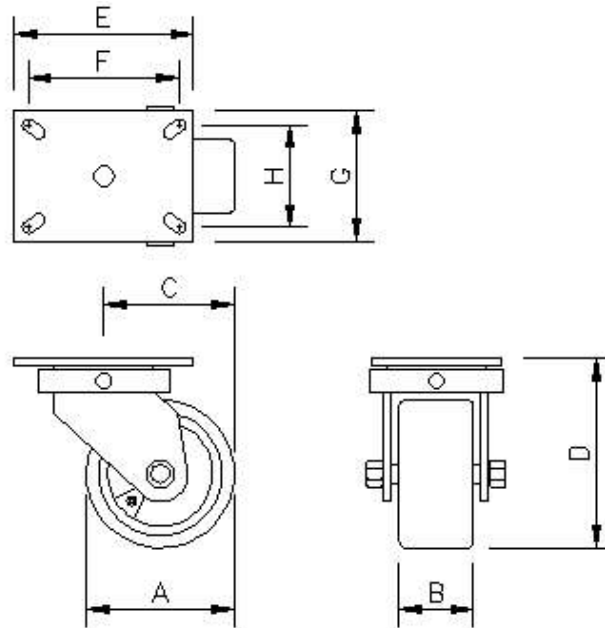

PART # SB5910