

# Sea Box, Inc.®

**CORPORATE OFFICE**  
 802 Industrial Hwy.  
 East Riverton, NJ 08077-1910  
 Tel: (856) 303-1101  
 Fax: (856) 303-1501  
[www.seabox.com](http://www.seabox.com)  
 e-mail: [sales@seabox.com](mailto:sales@seabox.com)



## 10' X 8' 6" Refrigerated ISO Cargo Container

10' Refrigerated	Length		Height		Width		Door Opening	
	Exterior	Interior	Exterior	Interior	Exterior	Interior	Height	Width
Feet/Inches	9' 9 3/4"	6' 11 5/6"	8' 6"	7' 5 3/16"	8' 0"	7' 5 1/16"	7' 3 11/16"	7' 6 3/16"
Metric	2,991	2,116	2,592	2,366	2,438	2,262	2,227	2,290

10' Refrigerated	Tare Weight w/ Machine	Payload	Gross Weight	Cubic Capacity	Thermal Leakage = U max @ 10° C mean temp
Lbs.	5,511	20,944	26,455	400 Cu. Ft.	28.2 BTU/hr. °F
Kg.	2,500	9,500	12,000	11.32 Cu. M.	12.9 Kcal/hr. °C

\* All dimensions are average. Exact specifications for each model are available.

**ALL NEW CONTAINERS ARE MANUFACTURED TO  
 THE LATEST ISO STANDARDS FOR 9 HIGH STACKING**

### — STANDARD FEATURES —

- ▶ Steel sides and roof
- ▶ Double full opening swing doors on one end with padlocks
- ▶ Air curtain
- ▶ Emergency escape hatch
- ▶ Forklift pockets
- ▶ Aluminum T-grade floors
- ▶ 4 rows of "E" Track cargo restraint system along interior side walls of container (these may all be used for numerous tie downs (along both wall in floor))
- ▶ 6 cargo tie downs (along both wall in the floor)
- ▶ 6 cargo tie downs high up on both walls (24 total tie downs)
- ▶ Interior electrical lighting system
- ▶ Access steps to non-slip roof
- ▶ Pressure relief port installed in rear cargo door panel
- ▶ Carrier refrigerated machinery features electrical supply as follows: 208/230, 380/460 Volts AC, 3 phase, 50 or 60 cycle
- ▶ Temperature range from -20° F to 70° F

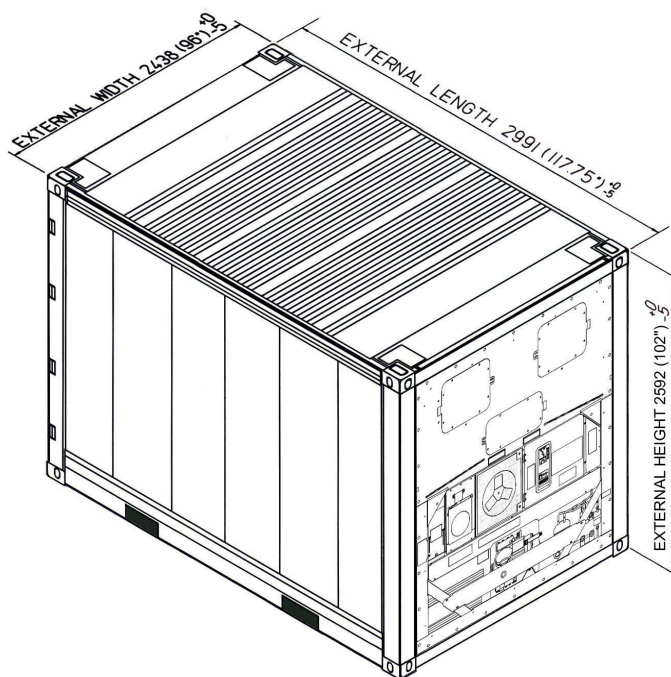

**PART # SB532.6**